



250 E

*Ride on pick&carry crane
with 25.000 kg capacity*



FEATURES

MAX CAPACITY 25.000 kg
 MAX BOOM EXTENSION 9,79 m
 MAX BOOM ANGLE 60°
 MIN BOOM ANGLE -6,5°
 WEIGHT 24.200 kg
 REMOVABLE COUNTER. 4.740 kg
 CONFORMITY 2006/42 CE; 2014/30 CE;
 2014/35 CE; 2000/14 CE; EN 13000

CHASSIS	6 wheels structure made in high quality steel, with internal counterweights, closed cabin as standard
WHEELS	Front: n°4 superelastic wheels 355/65 - R15" Rear: n°2 superelastic wheels 355/65 - R15"
TRACTION	Rear traction with differential axle with reduction gear, powered by electric motor AC – 30 kW controlled by inverter.
HYDRAULIC SYSTEM	Powered by electric motor AC – 33 kW controlled by inverter
BRAKES	N°4 brake shoes on front axle N°2 brake shoes on rear axle
STEERING	Rear steering by hydraulic motor installed on fifth wheel
BOOM	Manufactured in high quality steel, composed by four elements: main boom and three telescopic hydraulic sections with proportional extension.
POWER SUPPLY	Electric
BATTERY	96V - 1120 Ah
BOOM'S CONTROL	By can-bus joystick inside the cabin
DRIVE CONTROL	By pedals and steering wheel inside the cabin
SAFETY SYSTEM	Electronic load moment indicator (LMI) with display for load, boom's position and boom's angle control
OPTIONALS	Hydraulic winch, manual Jib, hydraulic Jib, radio remote control, non marking wheels, self levelling hydraulic forks, battery watering system, on board battery charger, carry deck.

"All specifications are subject to change. Consult Valla for latest specifications"

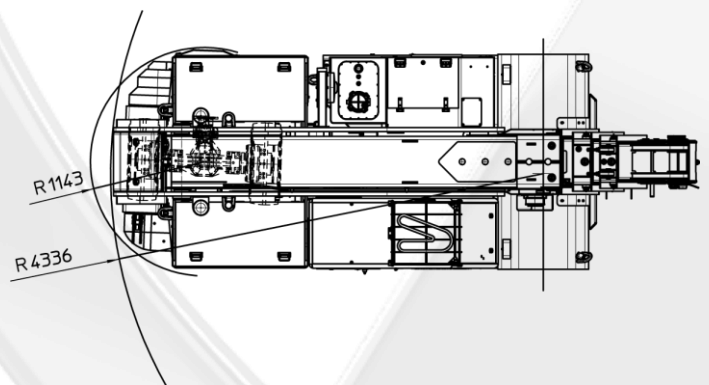
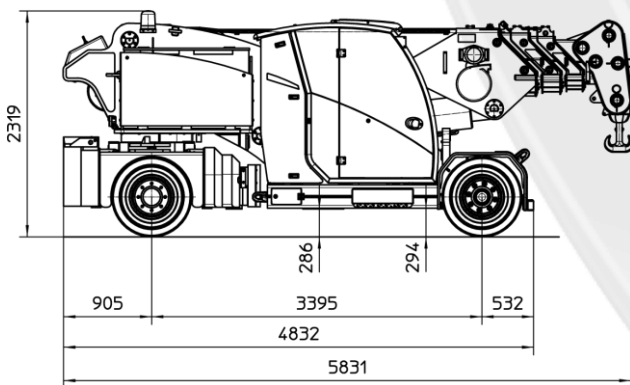
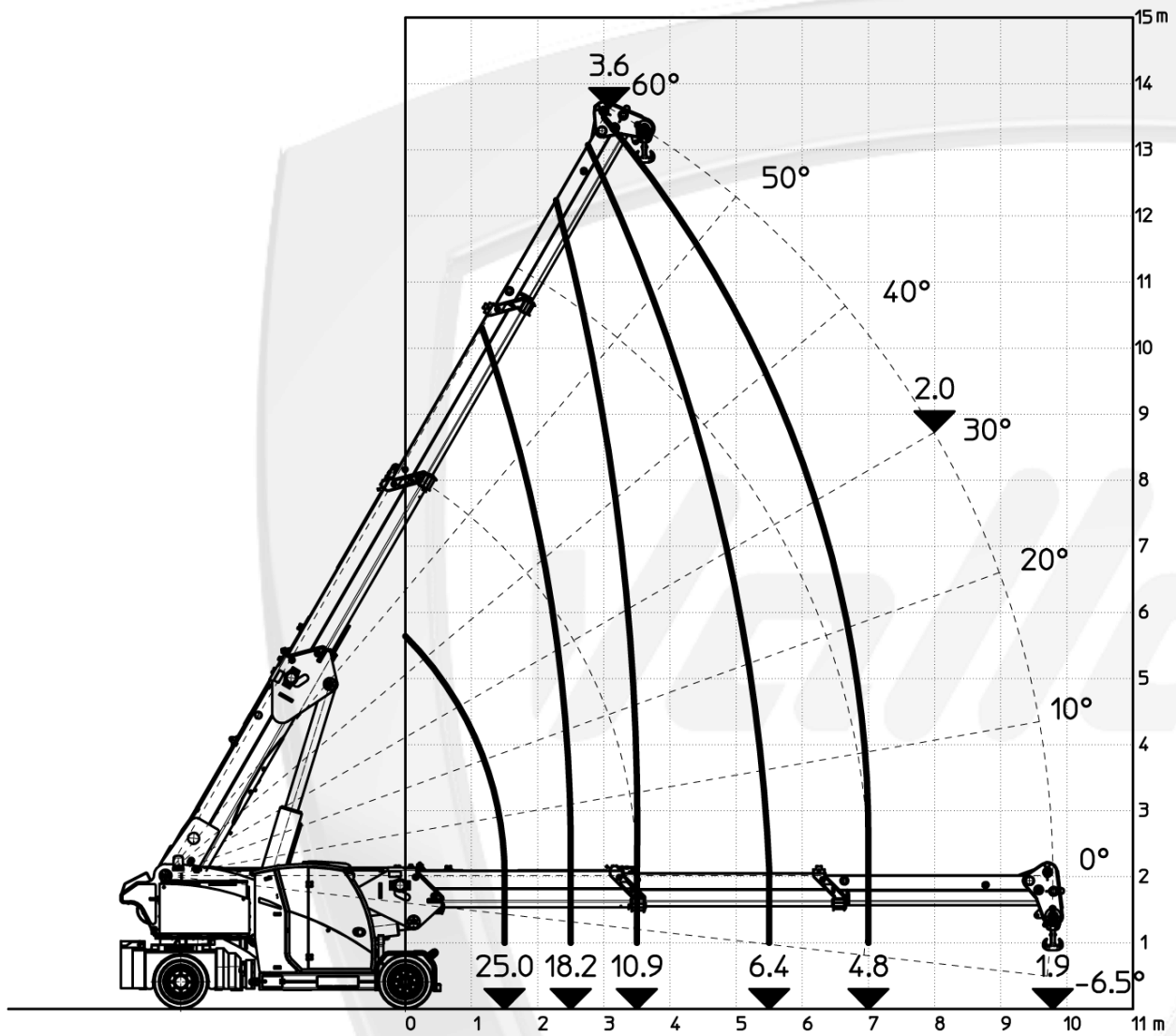

Valla
MANITEX

VALLA MANITEX SRL
Via Leonardo da Vinci 12
29016 - Cortemaggiore (PC) - ITALY

PHONE: +39 0523 256411
EMAIL: info@valla.com
SITE: www.valla.com