

VALLA 80D - TRX MOBILE TRACKED CRANE Max Capacity 8 t.

DIESEL POWERED



ENGINE: diesel HP 72 - 4 cylinders, water cooled.

TRANSMISSION: automatic (hydrostatic). Max speed 4 km/h.

CRANE FRAME: fabricated from preformed and welded steel plate with built-in counterweight. Hydraulic and independent outriggers.

TRACKED UNDERCARRIAGE: steel tracks with rubber pads. Two variable hydraulic motors.

BOOM: fabricated from preformed and welded steel plate with 5 hydraulic telescoping sections fitted with adjustable nylon wear pads. Boom slewing for unlimited and continuous 360°.

WINCH: hydraulically operated.

HYDRAULIC SYSTEM: powered by gear pump, electric proportional distributor controlled by 2 joysticks, filter, safety valves on all boom operations. Max pressure 280 bar.

DRIVER'S OVERHEAD GUARD: steel frame with metal checker plate and full visibility.

WEIGHT: Kg. 12.000~.

OPTIONAL EXTRAS: L.M.I. (electronic Load moment Indicator), hydraulic chain hoist, man bucket, remote control, metal/glass enclosed cab, manual jib extension, LPG conversion.

Valla S.p.A.

Via Piacenza, 45 - 29010 Calendasco - Piacenza - ITALIA
Tel. 0039 0523 762025 - 762004 - Fax 0039 0523 760531
Internet: www.valla.com - email: info@valla.com

The crane complies with following international standards:

- I.S.P.E.S.L.
- DIN 15018(1,3) - 15019 (1) Class H2 B3
- ANSI - 1994

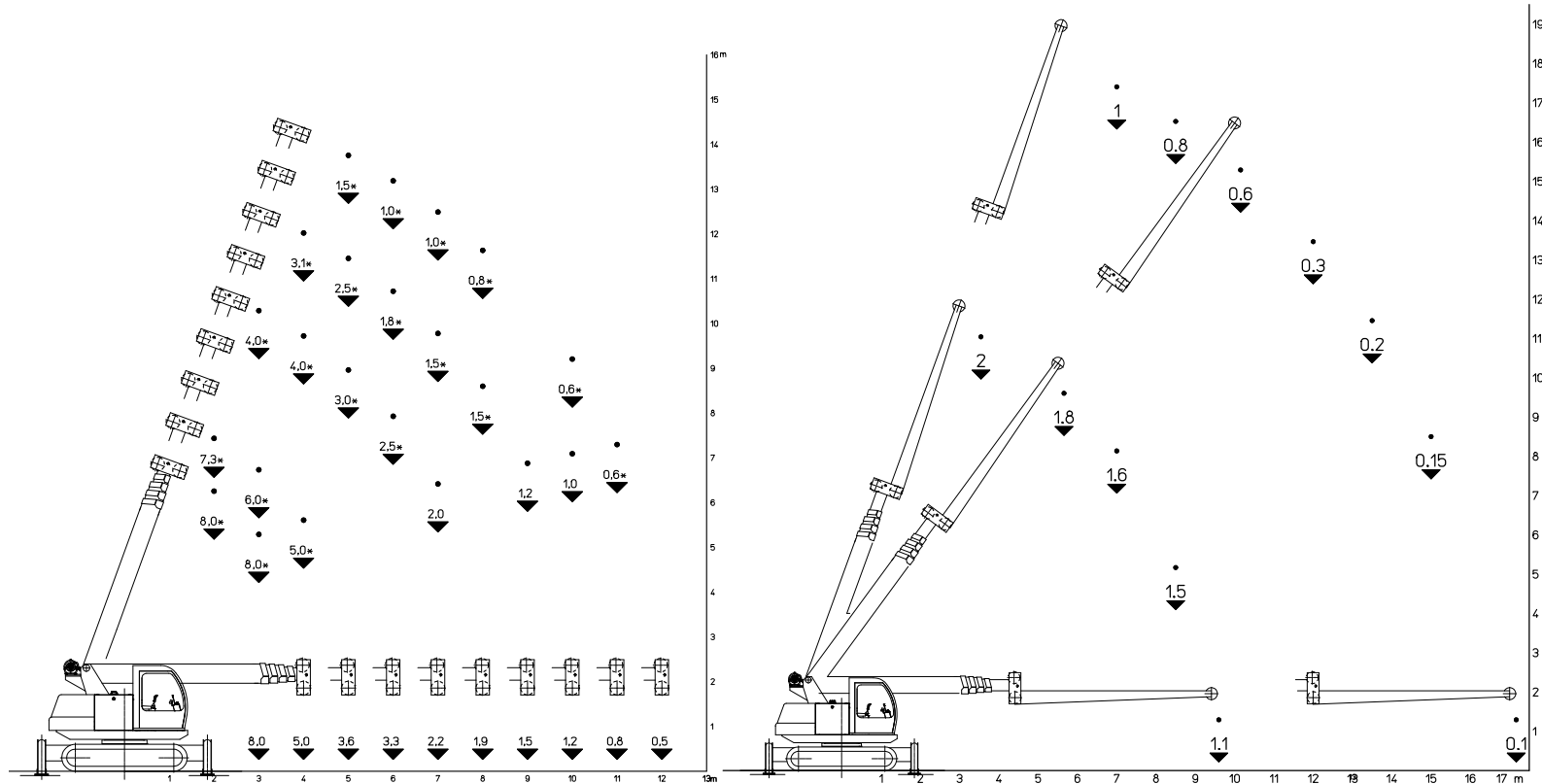

MODEL 80D TRX

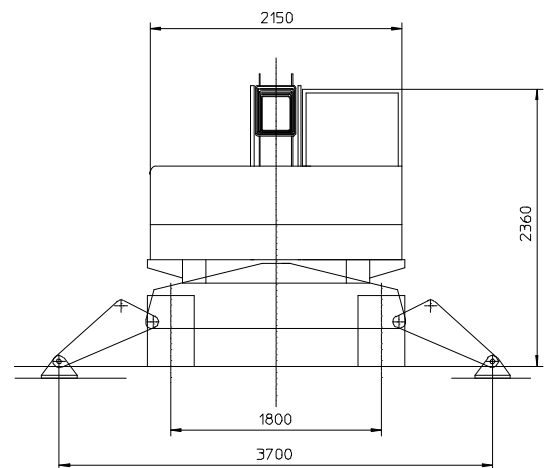
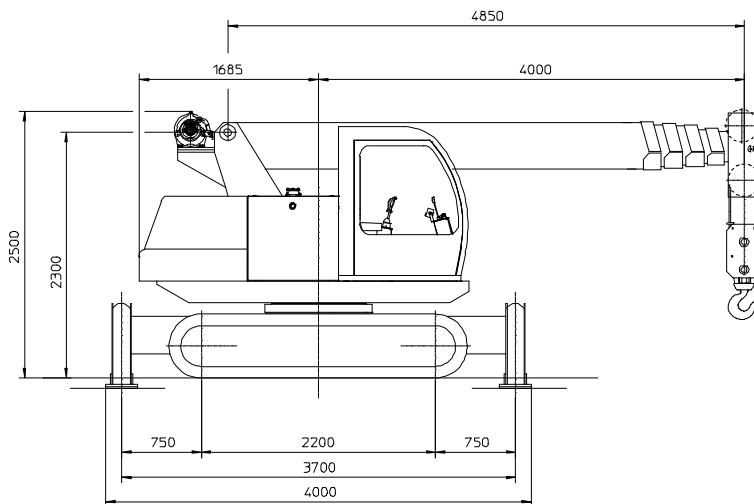

mm

Valla S.p.A.

Via Piacenza, 45 - 29010 Calendasco - Piacenza - ITALIA
 Tel. 0039 0523 762025 - 762004 - Fax 0039 0523 760531
 Internet: www.valla.com - email: info@valla.com

